

RICHMOND GEAR INSTALLATION INSTRUCTION VIDEO

It is our strong recommendation that you read this set of instructions very carefully before beginning the actual gear set installation, since no gear set can be expected to withstand the abuse of performance applications if not carefully and properly installed. An extra ten minutes at this point could spell the difference in regard to safety and extended gear life...or a prematurely failed gear set. Don't rush the installation! It can be a foolish waste of time.



The RICHMOND GEAR INSTALLATION INSTRUCTION VIDEO is designed for you to see how to properly install ring and pinion gear sets.

Applications covered in this video include:

American Motors • Chevrolet 10 bolt 1955-1964 • Chrysler 8.25" • Chrysler 8.75" and 9.25" • Corvette 1955-1962 • Corvette 1963 - present • Dana 28-44-60 • Ford 8"-8.8"-9"-7.50" • GM 10 Bolt • GM 12 Bolt car and truck • Oldsmobile and Pontiac 1957-1964 • Toyota

Available through your local RICHMOND GEAR Distributor.

VERIFY RATIO BEFORE ASSEMBLY

STEP 1. Remove the gears to be replaced and thoroughly clean both the gear carrier and housing with solvent to remove any gear/bearing residue, which could lead to abrasive failure of the new gear set. After cleaning, dry-wipe (or air-dry) all disassembled parts, housings, and covers.

STEP 2. Examine the ring gear mounting surface for nicks or burrs which might prevent total landing of the newly installed ring gear. Ring/pinion tooth depth variations can result from a ring gear that is "cocked" on its mounting surface. If a ring gear spacer is to be used,

also check it for similar surface imperfections, dressing these with block backed pieces of grit paper or a small file. Following material removal (from ANY part of the assembly), bathe the pieces in the solvent and wipe or air-dry.



Spacers not normally recommended

NOTE:

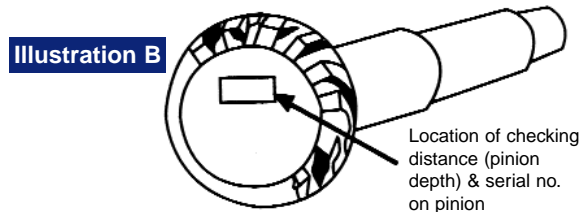
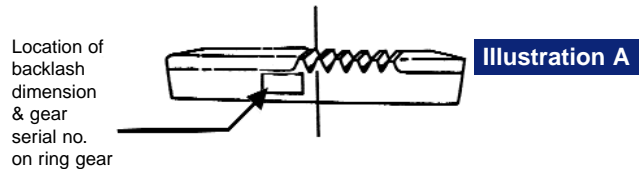

STEP 3. Study the illustrations provided with these instructions. Familiarize yourself with the terms "backlash" and "pinion depth" (sometimes called checking distance). Each set of gears is a matched pair which has been prerun on a gear test machine. Consequently, the pair should never be mixed with other rings or pinions. Also, since all gear sets have been run-checked, specific settings are supplied with each ring/pinion pair. These specifications vary from set to set. Backlash settings are marked on the outside diameter face of the ring gear as follows (see illustration A): Ref: BL.008, which means a backlash figure of .008 inch at the closest point. Pinion depth settings (or checking distance) are marked on the face of the pinion gear as follows (see illustration B): Ref: CD 2.799, which means distance of 2.799 inches from centerline of the ring gear to pinion face. Dimensional variations for backlash SHOULD NOT EXCEED .004" variation. Example: If backlash is .008, the backlash -- including maximum variation -- should be .008-.012.

STEP 4. When installing the pinion gear you must check its depth in the housing as per the pinion depth dimension. Add or subtract pinion depth shims to arrive at the checking distance etched on the surface of the pinion face. (See illustration C.) Refer to Helpful Hints & Additions to Richmond Gear Installation Instructions on pages 3 and 4.

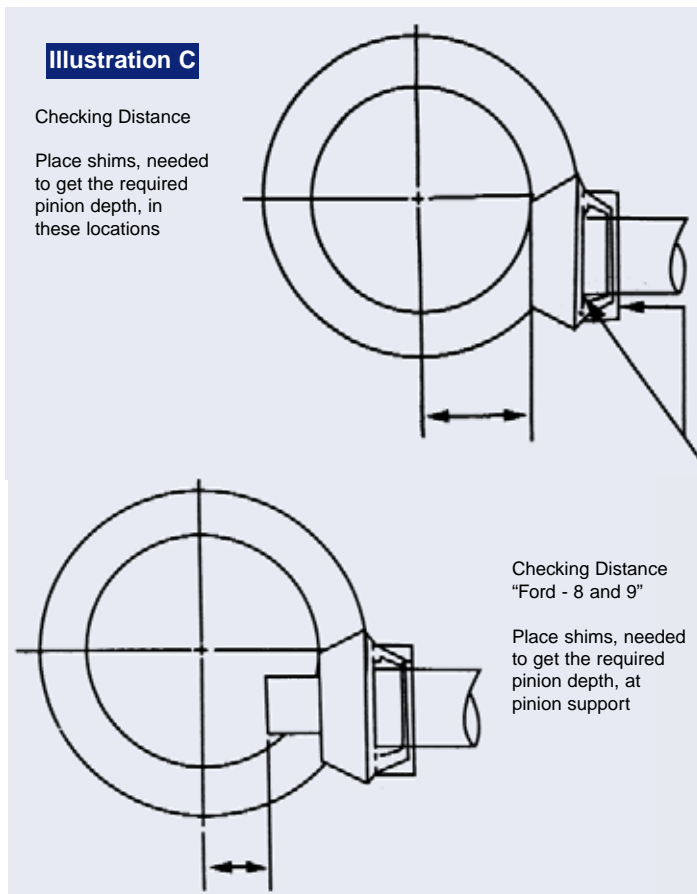

STEP 5. Using a new crush collar or preload shim pack, set the pinion rotating torque to 10-15 (used bearings) 20-25 (new bearings) inch pounds. For oval track applications when not using a cooling pump, set at 16-17 inch pounds on new bearings and 10 inch pounds maximum on used bearings.

STEP 6. After correct installation of the pinion gear, position the ring gear and check for backlash. Mount a magnetic-base dial indicator on the axle housing in such a way that the indicator plunger will be moving in a line that is tangent to rotation of the ring gear. This will provide you with a backlash reading which should conform to the figure etched on the side of the ring gear. Again, maintain a tolerance of .004 variation. Example: If backlash is .008, the backlash - including maximum variation - should be .008-.012. (Backlash is always

measured in 3 or more places equally spaced around in the ring gear.) Note: For oval track racing set BL at approximately .012-.014 inches.

STEP 7. Compensation for variations in this setting can be made by side-adjustment of the ring gear. Adjusting rings or side-shim packs can be changed to bring the backlash and rotating torque figures into tolerance. (Use same torque on gear bearings as on pinion bearings.) You are now ready to check the tooth contact pattern to assure that no accidental departures from the factory-marked specifications have been made. Apply a thin coat of RICHMOND GEAR compound ("Part # 55-0001-1") on gear teeth for best results. Tooth contact patterns should comply with those shown on next page. (Note rounded or bullet nose shape at heel end of pattern on Gear drive sides). See page 4 for patterns and additional installation hints.

If the pattern is not in those approximate positions, reset the pinion depth and reset gear backlash until the patterns are closer to the above diagram. Pinion and/or gear should not be adjusted to try to achieve a deeper pattern. The length of the pattern may vary with the amount of the load applied during the check procedure.

If satisfactory pattern results cannot be obtained after a reasonable adjustment, return the gear set to RICHMOND GEAR for evaluation. An accurate evaluation can not be obtained on a used set.

STEP 8. Fill the gear case with sufficient amount of RICHMOND GEAR 75-140 Synthetic Gear Lube with GL 6 rating, or better and maintain the proper level at all times. Proper maintenance is a must to protect your safety and working life of your gear set. Check oil level between scheduled oil change to insure that proper oil level is maintained. Inspect vent plug to insure it is clean and operating. Inspect oil leakage, excessive heating, or any unusual noise or vibration. Note: For oval track racing, add 2 to 3 additional pts. gear lube.

RICHMOND GEAR OIL



75-140 Synthetic Oil.

GL6 with Limited Slip Additive
1 U.S. Quart / 0.946 Liter

FINAL RESULTS

Properly designed, manufactured, and maintained RICHMOND GEAR gears, correctly assembled by you in a clean rigid gear box, and operated with the proper lubricant, should result in safe and satisfactory performance. Be sure you select the proper application for your gear set.

Any questions concerning these installation instructions must be forwarded to us for clarification at the following address:

RICHMOND GEAR
P.O. Box 238, Old Norris Road
Liberty, South Carolina 29657
TechLine: 864-843-9275
Email: tech@richmondgear.com

WARRANTY

Warranty is limited to material and/or workmanship defect at time of shipment from the factory, and in no event shall seller have any liability for consequential damages of any kind resulting from a breach of this warranty. This warranty will be void on all products that show evidence of misapplication, improper installation, abuse, lack of proper maintenance, negligence, or alteration from original design. This warranty is in lieu of any other warranties, either express or implied, INCLUDING ANY IMPLIED WARRANTIES OF MERCHANTABILITY OF FITNESS FOR ANY PARTICULAR PURPOSE.

ADDITIONAL INFORMATION

Buyer shall be solely responsible for determining the adequacy of the product for any and all uses to which buyer shall apply the product. The application by buyer shall not be subject to any implied warranty of fitness for that particular purpose. The manufacturer makes no warranty or representations, expressed or implied, by operation of law or otherwise as to the merchantability or fitness for a particular purpose of the goods sold hereunder. Buyer acknowledges that it alone has determined that the goods purchased hereunder will suitably meet the requirements of their intended use. In no event will the manufacturer be liable for consequential, incidental or other damages.

These instructions do not purport to cover all details or variations in equipment, nor to provide for every possible contingency to be met in connection with selection, installation, operation, lubrication, and maintenance. Should further information be desired or should particular problems arise which are not covered sufficiently for the purchaser's purpose, the matter should be referred to RICHMOND GEAR.

BREAK IN

A new ring and pinion installation, especially a high numeric ratio with new bearings, can cause an excessive heat buildup in the rear end and cause softening of the gear teeth and bearings if a break in is not performed.

Street vehicles should be driven at normal street driving speed for approximately 10 miles, then stop and let cool for 30 minutes. Do this 2 to 3 times. Towing vehicles need approximately 200 to 300 miles of normal street driving before being used for towing.

On circle track race cars make approximately 6 to 8 laps at slow speed, then let cool for 30 minutes. Make 6 to 8 more laps at slow speed, then 2 to 3 laps at full speed, then let cool again for 30 minutes.

Drag cars need only an initial run-in since they are driven short distances and heat is not normally a problem with proper lube and backlash allowance.

NOTE: If after the above break in is performed, overheating of the rear end is suspected, repeat the final portion of the break in procedures.

HELPFUL HINTS & ADDITIONS TO RICHMOND GEAR INSTALLATION INSTRUCTIONS

After completely reading instructions, go back to step #4. The following group of shim thickness are only if you do not have access to a pinion depth gauge or the old shim from the old pinion to start with. G.M.- .035, Ford 8-9" - .020, Ford 8.8 - 7.5 - .030, All Dana's- .035, 8-3/4 x 1-3/4 pin, - .090, 8-3/4 x 1-7/8 pin, - .020, Mopar- 9-1/4 - .020.

Pinion depth shims are located underneath the rear pinion bearing cone that is pressed on pinion with exception of the Dana Models. Dana pinion depth shims are underneath the rear pinion bearing cup in the housing. Dana carrier bearing preload shims are between carrier and bearing cone. All others are on the outside of bearing cup unless spanners are used as in the Ford 8 and 9 inch, both 8-3/4 and Mopar 9-1/4. Ford 8 and 9 inch pinion depth is regulated by shims between pinion support and chuck or center section.

Step #5 - If crush collar is used to set bearing preload, do not use until you have established pinion depth and backlash and you are satisfied with the pattern you get. You can simulate pinion bearing preload by tightening pinion nut until the right preload is achieved with only motor oil on the pinion bearings. The crush collar and pinion seal should be last to install.

TOOTH CONTACT CHART

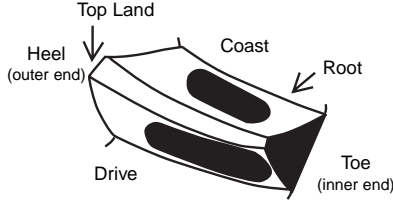
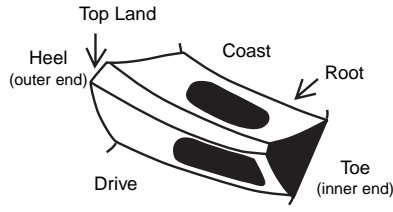
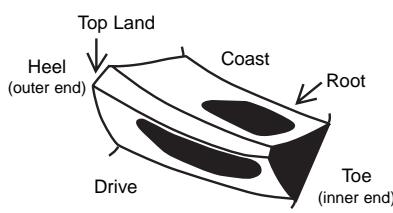
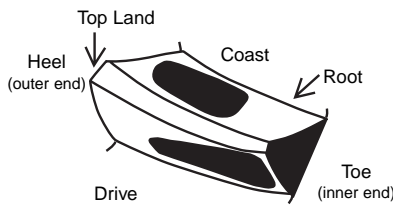
	Ring Gear Tooth Contact	Coast Side	Drive Side	Condition	Remedy
A		49-Series Ideal Pattern		IDEAL PATTERN	V/A
B		69-79-Series Ideal Pattern		IDEAL PATTERN	N/A
C		All Series - Pattern Too High		HIGH TOOTH CONTACT heavy on the top of the drive gear tooth profile	Move the Drive PINION DEEPER into MESH.
D		All Series - Pattern Too Low		LOW TOOTH CONTACT heavy on the root of the drive gear tooth profile	Move the Drive PINION OUT of MESH.

TORQUE SPECIFICATIONS

RING GEAR BOLTS GRADE 8

3/8" x all lengths	45-50 ft lbs.
7/16" x all lengths	60-65 ft lbs.
1/2" x all lengths	100-110 ft lbs.

CARRIER CAP BOLTS

7/16" (5/8" head)	60-65 ft lbs.
1/2" (3/4" head)	80-85 ft lbs.

Step #7-G.M. rear cover style housings use shims on the outside, between bearing cup and housing, adjusting backlash and carrier bearing preload. If starting with a bare housing, or you are installing a spool or different carrier, before you mount the ring gear, establish equal shim pack on each side of carrier and enough to create a drag when you slide it in and out of the housing by hand. Keep in mind you should keep the thickest shim next to the bearing cup. With a little loctite on the threads of the ring gear bolt, mount

gear to carrier or spool. After adjusting shim pack to get proper backlash and once you have established your pattern, remove carrier and pinion. Now is the time to install crush collar and pinion seal. NOTE: Always use loctite on the pinion nut. If you do not have a rear end housing spreader, you will have to work at installing the carrier once you add more shim to preload the carrier bearings. As a rule of thumb all carrier bearings will require .010 preload. After adding .005 to each side of the shim pack, coat surfaces of the shims with axle bearing grease to hold them in the housing, make sure the cups stay straight. Using a plastic or brass hammer, gently pound on bearing cups side to side until carrier has seated in housing. Again, it is important that you keep the cups straight during this operation. A spreader is almost necessary for all Dana Model rear ends. Torque caps to proper torque value.