

Richmond Super T-10 Four Speed

Dimensions

Available in G.M. Applications only.

The Richmond Super T-10 is a four speed countershaft helical gear transmission synchronized in all forward gears. First and reverse are constant mesh to prevent gear clash. Strut-type synchronizers are provided for longer life and easier shifting. The T-10 is used in applications for performance type automobiles and light trucks. The Richmond Super T-10 is the NASCAR standard.

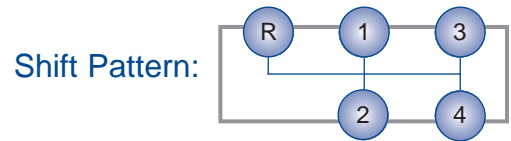
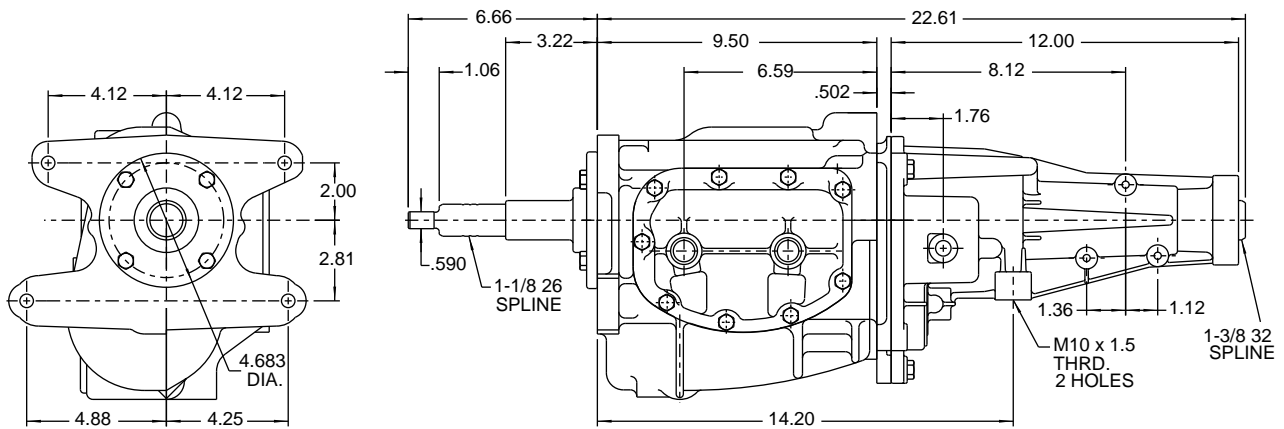
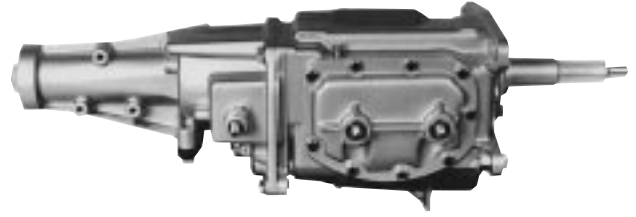

General Specifications

Part No.	Description	1st	2nd	3rd	4th	Rev.	Torque
1304000070	2.43 "S" Ratio	2.43	1.61	1.23	1.00	2.35	375 Ft. Lbs.
1304000069	2.64 "W" Ratio	2.64	1.75	1.34	1.00	2.55	325 Ft. Lbs.
7021090	2.64 "X" Ratio	2.64	1.60	1.23	1.00	2.55	325 Ft. Lbs.
1304000072	2.88 "CC" Ratio	2.88	1.91	1.33	1.00	2.78	300 Ft. Lbs.
1304000062	2.88 "Y" Ratio	2.88	1.74	1.33	1.00	2.78	300 Ft. Lbs.
1304000071	3.42 "Z" Ratio	3.42	2.28	1.46	1.00	3.51	286 Ft. Lbs.

Center Distance	3.25 Inches
Oil Capacity	2.4 U.S Pints
Approximate Dry Weight	70 Lbs.
Case & Extension Housing	Aluminum
Controls	Side Lever



Richmond Super T-10 Four Speed

Assemblies

Part No.	Description
1304000069	2.64 W Ratio
1304000070	2.43 S Ratio
1304000072	2.88 CC Ratio
7021090	2.64 X Ratio
1304000062	2.88 Y Ratio
1304000071	3.42 Z Ratio

View #	Part No.	Description
1	AT10107A	Rear Adapter Assembly
2	T101451/2C	Adapter Gasket
3	T10146 A	Adapter Gasket
4	T1024	Reverse Shift Fork
5	T1035	Reverse Idler Shaft
6	T1088A	Thrust Washer
7	T22110A	Ext. Housing Seal
8	T85B115	Side Cover Gasket
9	T85G25	Spacer
10	T85G26	Input Needle Bearing
11	T86166	Cluster Needle Bearing
12	T89C54	Front Bearing Retainer Seal
14	T90A108	Control Housing Seal
15	8680003	Thrust Washer (2 Required)
16	103565	Taper Pin
17	103905	Woodruff Key
18	1000127050	Extension Housing Bushing
19	1000130010	Mainshaft Bearing
20	1000130010	Input Bearing
21	1304027001	Front Bearing Retainer
22	1304053003	Cluster Bearing Spacer
23	1304053004	Cluster Bearing Washer
24	1304068001	Cluster Shaft
25	1304070002	Reverse Gear All Ratios
26	1304077008	Cluster Gear 2.64 W Ratio
	1304077009	Cluster Gear 2.43 S Ratio
	1304077010	Cluster Gear 2.64 X Ratio
	1304077012	Cluster Gear 2.88 Y Ratio
	1304077016	Cluster Gear 3.42 Z Ratio
	1304077017	Cluster Gear 2.88 CC Ratio
27	1304080004	First Gear W, S, CC, X, Y, Ratios
	1304080023	First Gear Z Ratio
28	1304080001	Second Gear S, W, CC, Z Ratios
	1304080020	Second Gear X, Y Ratios
29	1304080019	Third Gear X, CC, Y Ratios
	T10S11	Third Gear S, W Ratios
	T10U11	Third Gear Z Ratio

- Continued -

Replacement Parts & Assemblies

For view # see exploded view on page 35.

View #	Part No.	Description
30	1304084004	Reverse Gear Z Ratio
	1304084005	Reverse Idler Gear W, S, CC, X, Y Ratios
31	1304085006	Input Drive S Ratio
	1304085016	Input Drive W, X, Ratio
	1304085022	Input Drive CC, Y Ratio
	1304085023	Input Drive Z Ratio
32	1304091002	Brass Snychro Ring
33	1304096002	Shift Fork
34	1304097004	Side Cover
35	1304103001	First Gear Sleeve
36	1304110002	Speed O Gear All Ratios
37	1304171005	Mainshaft
38	1304193101	Thrust Washer
39	1304193002	Thrust Washer
40	1304566005	Extension Housing Assy.
41	1304584002	Reverse Idler Gear Assy. All Ratios
42	1304590007	3-4 Synchro Assy. w/o brass
43	1304590008	3-4 Synchro Assy. w/brass
44	1304590009	1-2 Synchro Assy. w/o brass
45	1304590010	1-2 Synchro Assy. w/brass
46	1304598003	Reverse Shift Cam Assy.
47	1304603010	Detent Kit
48	1304603011	Small Parts Kit (Needle Bearings, Snap Rings, Spacers & Washers) ((Not Shown))
	1304603012	Gasket Kit: 2, 3, 8 & 59 ((Not Shown))
49	456876	Lock Pin
50	4652U	Spacer
51	4734A-E	Snap Ring
52	4821A	Snap Ring
53	4829	Snap Ring
54	7880010	Needle Thrust Bearing
55	6291034	Synchro Key and Spring Kit
56	6680025	3-4 Shift Cam Assy.
57	6692012	1-2 Shift Cam Assy.
58	7180049	Main Case
59	8195086	Bearing Retainer Gasket
60	8280040	"O" Ring
	Sy-1310	Slip Yolk Turbo 400
	Sy-1330	Slip Yolk Turbo 400

Richmond Super T-10 Four Speed Exploded View

